

J. L. HAYDEN.
Machinery for Grinding Cocks.

No. 223,507.

Patented Jan. 13, 1880.

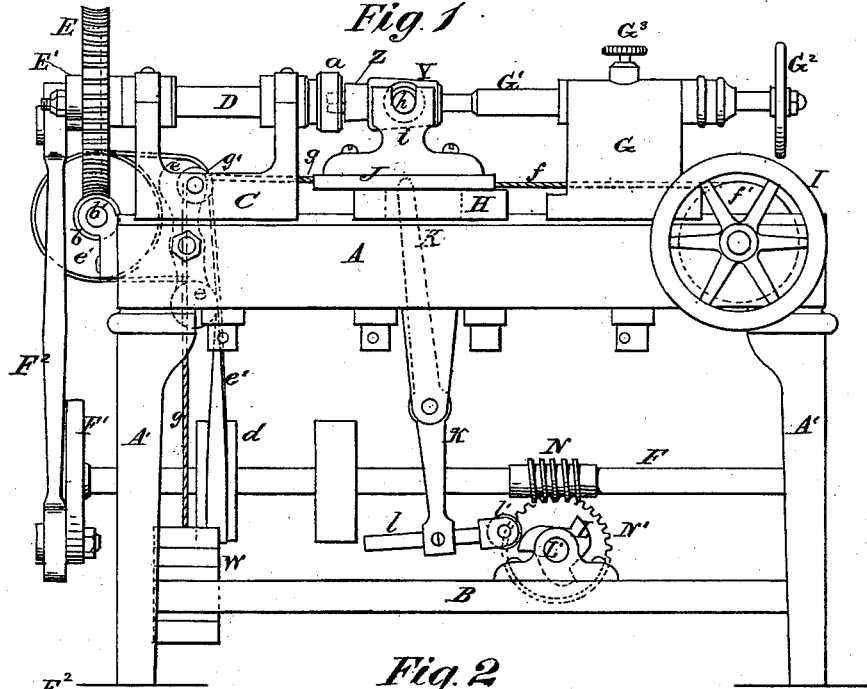

Fig. 2

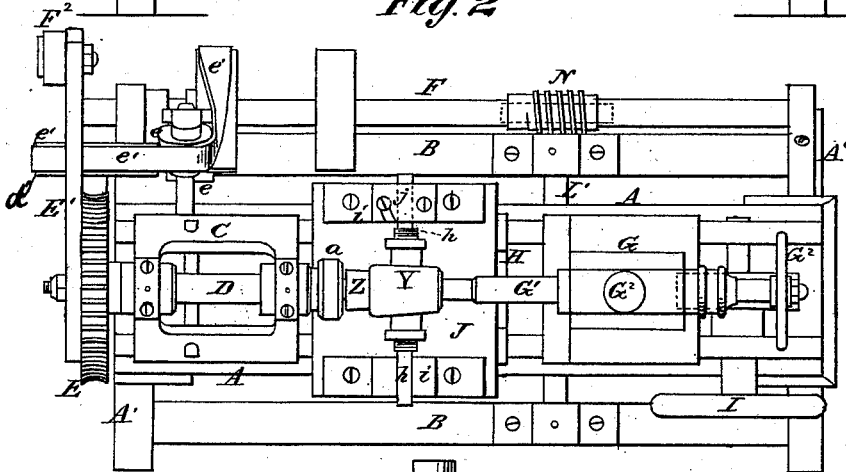
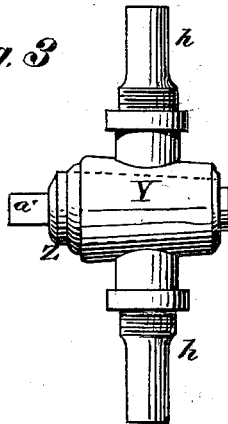

Fig. 3



Witnesses:
S. Campbell
E. J. [Signature]

Inventor:
Joseph L. Hayden
By Attorney, S. Campbell.

J. L. HAYDEN.
Machinery for Grinding Cocks.

No. 223,507.

Patented Jan. 13, 1880.

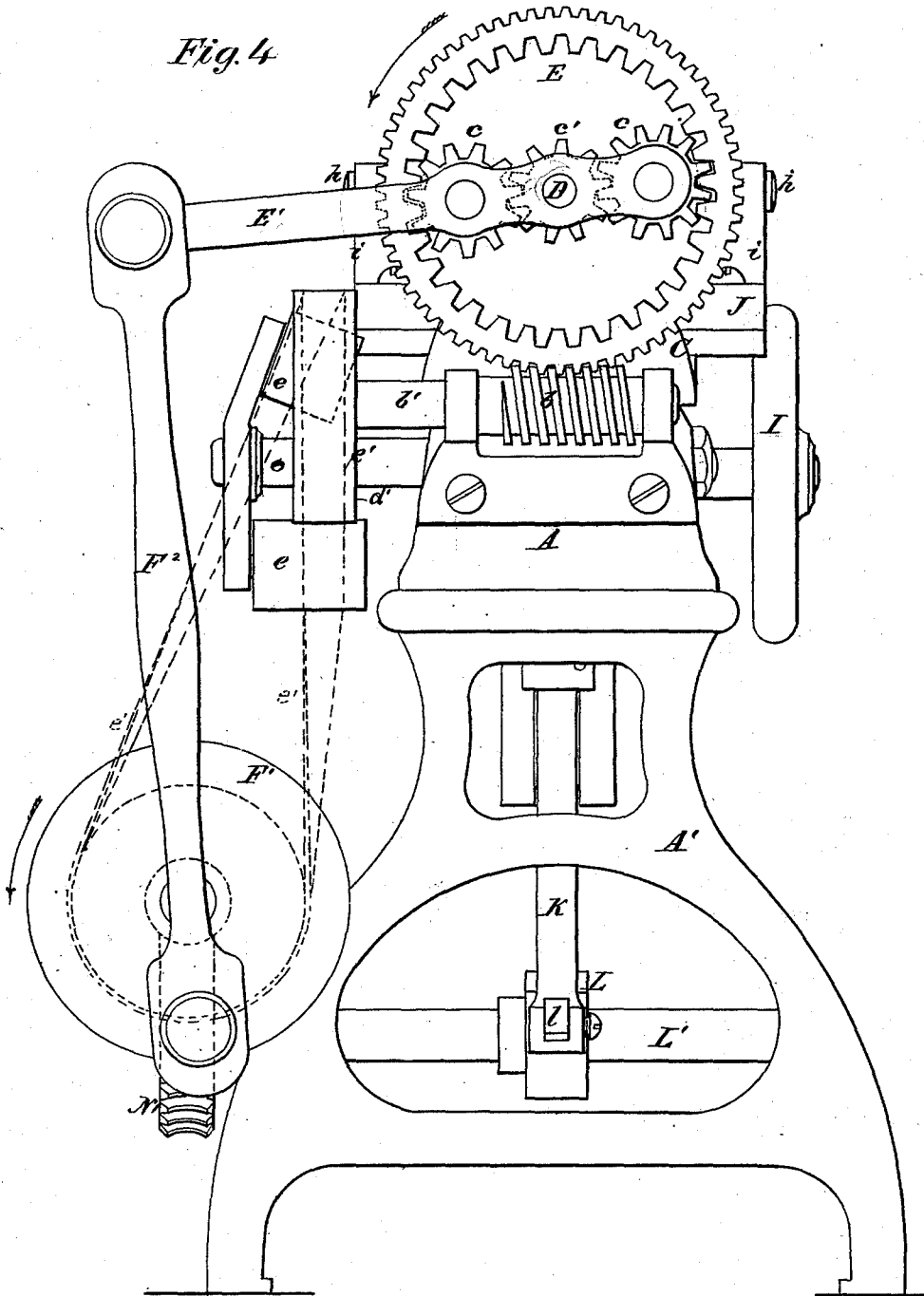

Witnesses.
J. Campbell
E. D. [Signature]

Inventor
Joseph L. Hayden
By Attorney R. T. Campbell.

UNITED STATES PATENT OFFICE.

JOSEPH L. HAYDEN, OF CAMBRIDGEPORT, MASSACHUSETTS.

MACHINERY FOR GRINDING COCKS.

SPECIFICATION forming part of Letters Patent No. 223,507, dated January 13, 1880.

Application filed December 4, 1879.

To all whom it may concern :

Be it known that I, JOSEPH L. HAYDEN, of Cambridgeport, in the county of Middlesex and State of Massachusetts, have invented new and valuable Improvements in Machinery for Grinding Cocks; and I do hereby declare that the following is a full, clear, and exact description of the construction and operation of the same, reference being had to the annexed drawings, making a part of this specification, and to the letters and figures of reference marked thereon.

Figure 1, Sheet 1, is an elevation of the front of the improved machine. Fig. 2, Sheet 1, is a top or plan view of the machine. Fig. 3, Sheet 1, is a plan view, enlarged, of a cock having trunnions applied to it for sustaining it in its rest on the machine to be ground. Fig. 4, Sheet 2, is an enlarged elevation of one end of the machine.

Similar letters of reference indicate corresponding parts on the several figures.

This invention relates to machinery which is designed for grinding stop-cocks, whether of brass or other metal, and fitting the plugs into their barrels, so as to prevent leakage.

The nature of my invention consists, mainly, in certain novel means, hereinafter explained, whereby the plugs of the cocks receive rapid oscillating motion about their axes, and at the same time a slow continuous rotary motion at the same time that the barrels are fed up to the work on the plugs by a pressure which may be increased or diminished at the will of the person who attends the machine.

Other features of my invention which enter into the operation of the machine to produce perfect work will be understood from the following description.

The main frame of the machine is constructed very much like that of a turning-lathe, A designating the bed or ways, which are in a horizontal plane, and mounted on legs A' A', connected rigidly together by horizontal bars B. C designates a head-stock, which is rigidly bolted on top of the ways or bed A at one end thereof, and which has a horizontal spindle, D, applied in suitable journal-boxes, which spindle has a recessed head, *a*, on one end, adapted to receive the square head *a'* of a cock-plug, Z.

On the opposite end of the spindle D is

loosely applied a worm-screw wheel, E, the perimeter-teeth of which engage with a worm-screw, *b*, on a shaft, *b'*, which is at right angles to the spindle D. The wheel E has also inside teeth, as shown in Fig. 4, with which two pinions, *c c*, engage, that are loosely applied on studs fixed to a vibrating lever, E'. The pinions *c c* engage with a pinion, *c'*, which is keyed fast on the outer end of the spindle D, on which latter the lever E' plays freely.

A continuous rotary motion of the spindle D is effected by power transmitted through the worm-wheel *b*, gear-wheel E, loose pinions *c c*, and fixed pinion *c'*.

The worm-screw shaft *b'* receives a properly slow motion from a main driving-shaft, F, by means of a pulley, *d*, idlers *e e*, belt *e'*, and a pulley, *d'*, which latter is fast on said shaft *b'*. Shaft F may receive rotation from any convenient prime motor.

The pinion-carrying lever E' receives vibrations from a crank-wheel, F', on shaft F, acting through the medium of a connecting-rod, F². (Shown in Fig. 4.)

The spindle D receives an oscillating motion about its long axis from the action of the vibrating lever E' loosely mounted on spindle D, internally-gear wheel E, loose pinions *c c*, and fixed pinion *c'*.

G designates a tail-stock, which is rigidly secured on the bed A, near the right-hand end thereof, and which bears a centering-rod, G', which is endwise adjustable by means of a hand-wheel, G², and can be rigidly fixed by a hand-screw, G³. The longitudinal axis of this centering-rod G coincides exactly with the axis of the spindle D, as shown in Figs. 1 and 2, and it is used for holding centrally in the machine the cock-plug Z and preventing end play thereof during the grinding operation.

Between the head-stock and the tail-stock a horizontal plate, H, is rigidly secured on the top of the bed or ways A, which is channeled on top and adapted to support and guide a carriage, J, that receives a reciprocating movement toward and from the chuck or head *a* of the spindle D. This carriage is connected by a chain, *f*, to a grooved wheel, *f'*, having a hand-wheel, I, on its shaft, by which the carriage can be moved back to adjust a cock into position for grinding or to remove a finished cock. The carriage is also provided with a

chain, *g*, which passes over a loose pulley, *g'*, and has attached to its depending end any number of weights *W* which it may be desired to use. These weights *W* keep the barrel *Y* of the cock up to the work of grinding and fitting, the amount of pressure being regulated by increasing or diminishing the weight on the chain *G*.

The cock-barrel *Y* to be operated on has two trunnions, *h h*, screwed into its branches, as shown in Figs. 2 and 3, which are supported in pillow-blocks *i i*, fixed on the carriage *J*, and which allow the barrel to find its center with respect to the cock-plug held between the chuck and the back center. One of the pillow-blocks on carriage *J* is provided with a pivoted cap, *j*, for covering one of the trunnions *h*.

K, Fig. 1, is a lever, the upper end of which passes through an oblong slot through plate *H*, and enters freely a depression made in the bottom of carriage *J*. (Shown in dotted lines.) The lower end of this lever *K* has adjustably secured to it a rod, *l*, bearing on one end an anti-friction roller, *l'*, which is designed to be acted on by one or the other of the leaves of a three-throw cam or tappet, *L*, fixed on a horizontal transverse shaft, *L'*, journaled on frame-bars *B B*. The object of this contrivance is to free the barrel *Y* from its plug *Z* when the operation of grinding is completed. To effect this the adjustable rod *l* is so set in the lever *K* that when the plug is ground sufficiently far into the barrel then the anti-friction roller *l'* will be struck by one of the tappets *L*, where-

upon the carriage *J* and the barrel *Y* will be loosened from the plug *Z*; then the carriage is freed from the plug by use of the hand-wheel *I*.

It is obvious that the center-rod *G'* must be moved away from the plug *Z* before this plug can be freed from its spindle-chuck. The releasing of the barrel from its plug, as above described, is entirely automatic, as the movements of the cam or tappet *L* are effected by means of a worm-screw, *N*, on main shaft *F* acting on a wheel, *N'*, on the cam-shaft *L'*. These movements should, of course, be properly timed with respect to the grinding movements given to the spindle *D*.

It will be seen from the above description of the mechanism immediately connected with the spindle *D* that this spindle receives a rapid oscillating motion about its axis, and at the same time it receives a continuous rotary motion, both of which motions combined I have found necessary in order to effect the accurate grinding and fitting of stop-cocks having cone-shaped plugs.

Having described my invention, what I claim as new is—

A reciprocating carriage, *J*, adapted to bear a cock-barrel, combined with a spindle, *D*, a wheel, *E*, pinions *c c'*, lever *E'*, crank-wheel *F'*, and a driving-shaft, substantially as described.

JOSEPH L. HAYDEN.

In presence of—
W. H. MARTIN,
A. B. CLAPP.